

1080P LCOS FULL HD PANEL

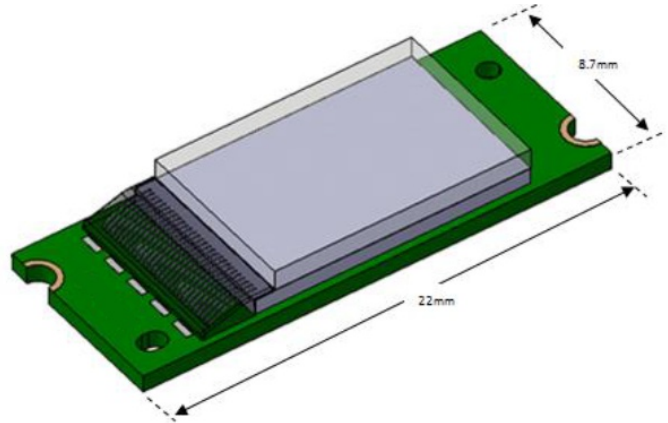

Brief Description

This LCoS HD panel provides 1080p resolution in a highly compact 0.37" diagonal format, enabling ultra-portable applications to deliver high definition resolution and high brightness in a still small form-factor. It provides excellent image quality with vivid colors while meeting the cost and power requirements of battery operated devices.

Its patented LCOS microdisplay architecture integrates all-digital smart electronics already in the display panel. An application specific SIMD processor then performs bit serial data manipulation to control each pixel. The intelligence is divided between the controller and the panel: the controller formats and arbitrates data flow to the panel, and the panel logic computes new pixel values and updates the pixels. This efficient methodology enables high bit depth liquid crystal drive while requiring minimal data bandwidth to the panel.

With this panel it is unnecessary to compromise on image quality in any applications.

Contact Information

Dresden Microdisplay GmbH
Maria-Reiche-Str 2
D-01109 Dresden

Benefits

- High resolution: Offers a rich user experience by supporting a full range of content including reading email attachments, web browsing, text, graphics, multimedia, and full-motion video
- Low power: Great for mobile, battery powered products, t360 mW average power for 1080p @ 6 CF/F
- Ultra-small: Form factor meets requirements for embedded applications
- High brightness: Fast LC enables saturated colors and high illumination on time
- White field support (RGBW) for brightness improvements
- Smooth gray scale at all brightness levels, matching the visual response of the eye
- No high voltage supply required (just 3.3V and 3.8V)

Info@Microdisplay.biz
www.microdisplay.biz
+49 (351) 41 88 97 60

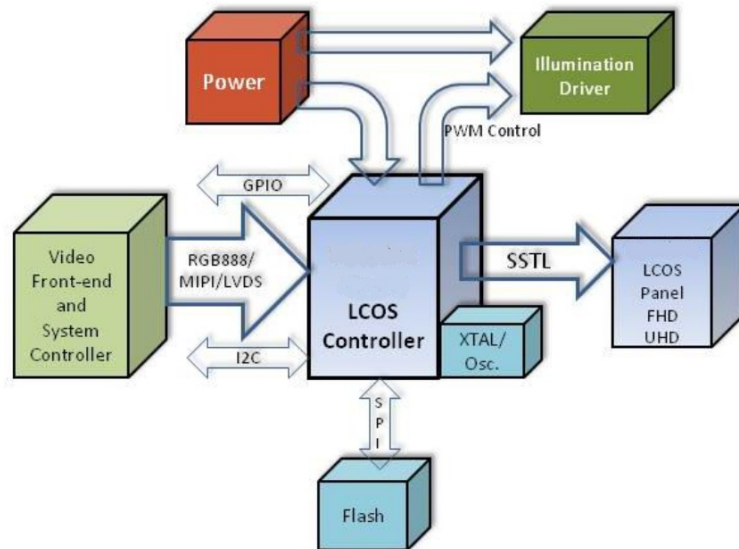

Features

Field sequential LCoS panel with digital drive

- Resolution 1080p (1920x1080)
- Display Diagonal 0.37" (active area)
- Pixel Pitch 4.27 μm
- Fill Factor 89.5%
- Contrast Ratio 500:1
- Reflectivity 70%
- Package Type Panel on mini PCB
- Package Height 8.7 mm
- Programmable on-the-fly
- Operating Temperature -10°C to 70°C
- Storage Temperature -40°C to 80°C

Multi-Resolution LCOS Controller

- Embedded frame buffer
- Accepts up to FullHD 1920x1080 resolution
- Video input formats: 24-bit RGB, YCbCr 422 or 444, MIPI, LVDS
- De-interlacing, Color Space Conversion and Keystone correction
- GPIO (STTL2) and I2C control interface
- Direct SPI Flash interface
- Illuminator control
- Power management

Contact Information

Dresden Microdisplay GmbH
 Maria-Reiche-Str 2
 D-01109 Dresden

Support

- Datasheet, errata
- Application notes
- Evaluation kit

Controller Specification

- Resolution Up to FullHD (1920x1080)
- Package Type TFBGA
- Package Dimensions 9 mm x 9 mm
- Ball Pitch 0.5 mm
- Power supplies 1.1V (core), 1.8V, 3.3V
- Power ~200 mW
- Light-on Duty Cycle 95%
- Operating Temperature -10°C to 85°C

Controller Benefits

- High quality and resolution vs. imager size
- Smooth gray scale at all brightness levels
- Sophisticated drive algorithms enable saturated colors and high illumination
- Programmable field rate & duration enables custom system performance optimization
- High reliability and long lifetimes suitable for consumer applications
- Compatible with LED or Laser light sources

Info@Microdisplay.biz
 www.microdisplay.biz
 +49 (351) 41 88 97 60